

Company Name: \_\_\_\_\_  
 Address: \_\_\_\_\_  
 City: \_\_\_\_\_ State: \_\_\_\_\_ Zip: \_\_\_\_\_  
 Phone: \_\_\_\_\_ Fax: \_\_\_\_\_  
 Date: \_\_\_\_\_ Contact: \_\_\_\_\_

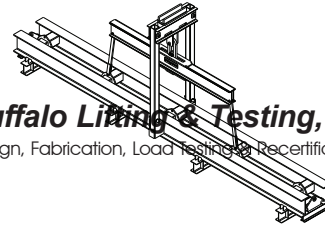

**Buffalo Lifting & Testing, Inc.**

Design, Fabrication, Load Testing, Recertification

Phone: (877) 232-6748  
 www.buffalolifting.com

Fax: (716) 672-8507  
 e-mail: blt@buffalolifting.com

# PLATE STYLE C-HOOK QUOTE SHEET

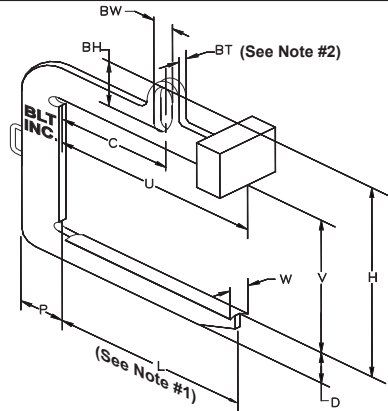

**CLOSE STACKING C-HOOK**  
 (HANDLES COILS FLUSH AGAINST VERTICAL SURFACE)

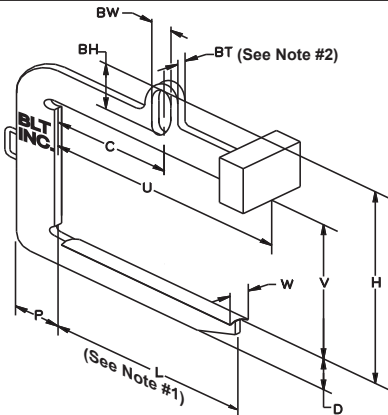

**LOW COST C-HOOK**  
 (LONGER UPPER ARM REDUCES COUNTERWEIGHT)

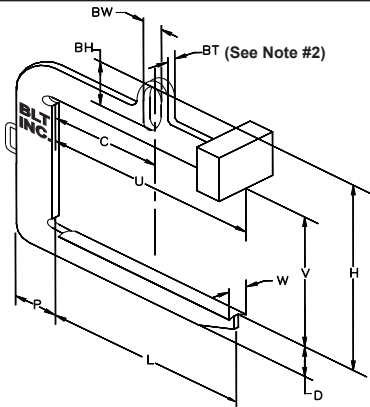

**SLIT COIL C-HOOK**  
 (LONGER LIFT ARM TO HANDLE MULTIPLE COILS)

- CLOSE STACKING C-HOOK
- LOW COST C-HOOK
- SLIT COIL C-HOOK

CAPACITY: \_\_\_\_\_ LBS.

- V \_\_\_\_\_ VERTICAL CLEARANCE
- C \_\_\_\_\_ DIST. TO CENTER OF GRAVITY
- U \_\_\_\_\_ UPPER ARM LENGTH
- L \_\_\_\_\_ LIFT ARM LENGTH
- D \_\_\_\_\_ LIFT ARM DEPTH
- W \_\_\_\_\_ LIFT ARM WIDTH
- P \_\_\_\_\_ VERT. POST DEPTH
- BT \_\_\_\_\_ BAIL THICKNESS
- BW \_\_\_\_\_ BAIL WIDTH
- BH \_\_\_\_\_ BAIL HEIGHT
- H \_\_\_\_\_ TOTAL HEIGHT

**Notes:** 1. Lifting arm length allows minimum coil width to be handled without protrusion of lift arm past edge of coil.  
 2. The center of gravity of the load must be centered under the lifting bail.  
 3. Please verify that the crane hook will fit the lifting bail size.

**Additional Specifications:**

\_\_\_\_\_  
 \_\_\_\_\_  
 \_\_\_\_\_  
 \_\_\_\_\_