

CONCRETE BARRIER LIFTER

- Automatic latch allows the lifter to be locked in the opened position and released when engaged with barrier creating a "Hands Free" operation.
- Move barriers quicker and easier without the use of damaging chain slings.
- Constructed from lightweight abrasion resistant material..
- Designed, manufactured and load tested to meet or exceed ASME B30.20 standards.
- Replaceable polyurethane pads are standard.

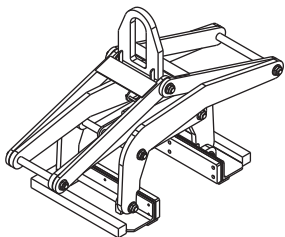

MODEL NUMBER	CAPACITY	UNIT WGT.
BLT8.5-CBL	8,500 LBS.	480 LBS.
BLT15-CBL	15,000 LBS.	695 LBS.

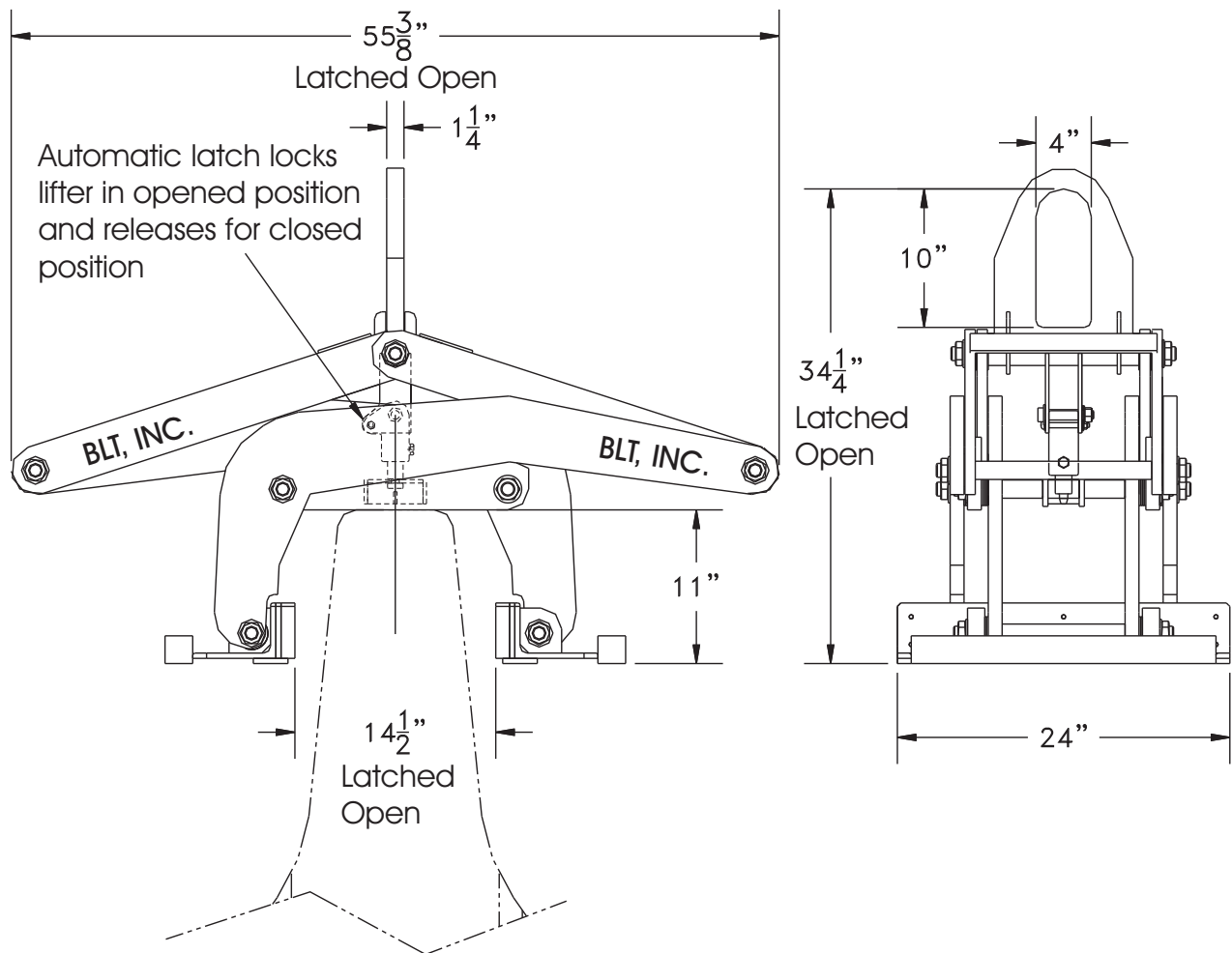
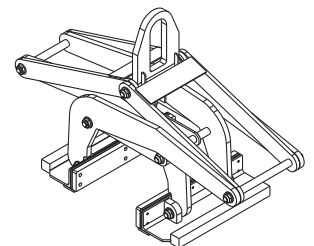

Buffalo Lifting & Testing, Inc.

69 Orchard Street, Fredonia New York 14063

Phone: (716) 672-6071 * Fax (716) 672-8507 * Toll Free: 877-232-6748

Website: www.buffalolifting.com * E-mail: blt@buffalolifting.com