

Fixed Crane Fork

- The Fixed Crane Fork converts an overhead crane into a maintenance-free low cost fork lift truck.
- External weld reinforcing plates add strength at critical stress areas.
- The Fixed Crane Fork is counterbalanced to hang level for easy insertion under the load.
- All lifters are proof tested to meet or exceed ANSI/ASME B30.20 standards and test certificate issued. Painted safety yellow and clearly marked on both sides with rated capacity to conform to OSHA standards.

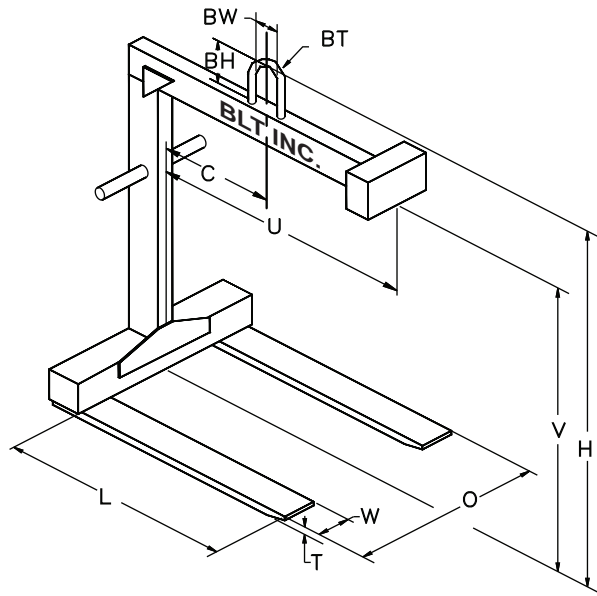

Model Number	Pounds		Inches (See Note #5)									Total Height H	Approx. Lifter Weight	
	Capacity (See Note #4)	Max Load Length (See Note #1)	Vertical Clear V	Center of Gravity C	Fork Length L	Fork Size		Outside Width O	Upper Arm Length U	Ball Size (See Note #2 & #3)				
						T	W			BT	BW			BH
BLT013048-FCF	1000	30	48	15	30	1 x 4		24	30	3/4 x 2 x 4			55	200
BLT013648-FCF		36		18	36	1-1/4 x 4		24	36	3/4 x 2 x 4			55	254
BLT014248-FCF		42		21	42	1-1/4 x 4		24	42	3/4 x 2 x 4			55	272
BLT014848-FCF		48		24	48	1-1/4 x 4		24	48	3/4 x 2 x 4			55	291
BLT023048-FCF	2000	30	48	15	30	1-1/2 x 4		24	30	3/4 x 2 x 4			56	292
BLT023648-FCF		36		18	36	1-1/2 x 4		24	36	3/4 x 2 x 4			56	323
BLT024248-FCF		42		21	42	1-3/4 x 4		24	42	3/4 x 2 x 4			56	390
BLT024848-FCF		48		24	48	1-3/4 x 4		24	48	3/4 x 2 x 4			58	457
BLT033648-FCF	3000	36	48	18	36	1-1/4 x 4		24	36	1 x 2 x 4			58	383
BLT034248-FCF		42		21	42	1-1/2 x 4		24	42	1 x 2 x 4			58	433
BLT034848-FCF		48		24	48	1-1/2 x 4		24	48	1 x 2 x 4			58	455
BLT043648-FCF	4000	36	48	18	36	1-1/2 x 4		24	36	1 x 2 x 4			58	429
BLT044248-FCF		42		21	42	1-1/2 x 4		24	42	1 x 2 x 4			58	485
BLT044848-FCF		48		24	48	1-3/4 x 4		24	48	1 x 2 x 4			58	543
BLT063648-FCF	6000	36	48	18	36	1-3/4 x 4		26	36	(3/4x1) x 2 x 6			62-1/4	575
BLT064248-FCF		42		21	42	2 x 4		26	42	(3/4x1) x 2 x 6			62-1/4	669
BLT064848-FCF		48		24	48	2 x 4		26	48	(3/4x1) x 2 x 6			62-1/4	697
BLT066060-FCF		60	60	30	60	2 x 5		32	60	(3/4x1) x 2 x 6			74-1/4	973
BLT084248-FCF	8000	42	48	21	42	2 x 5		28	42	(1x1-1/4) x 3 x 6			62-1/4	807
BLT084848-FCF		48		24	48	2-1/4 x 5		28	48	(1x1-1/4) x 3 x 6			64-1/4	893
BLT086060-FCF		60	60	30	60	2-1/4 x 5		32	60	(1x1-1/4) x 3 x 6			74-1/4	1102
BLT087272-FCF		72	72	36	72	2-1/2 x 5		36	72	(1x1-1/4) x 3 x 6			88-1/4	1463
BLT104848-FCF	10000	48	48	24	48	2-1/4 x 5		32	48	(1-1/4x1-1/2) x 4 x 10			70-1/4	983
BLT106060-FCF		60	60	30	60	2-1/2 x 6		32	60	(1-1/4x1-1/2) x 4 x 10			80-1/4	1345
BLT107272-FCF		72	72	36	72	2-3/4 x 6		36	72	(1-1/4x1-1/2) x 4 x 10			92-1/4	1803
BLT154848-FCF	15000	48	48	24	48	2-3/4 x 5		32	48	(1-1/2x1-1/2) x 4 x 10			70-1/4	1222
BLT156060-FCF		60	60	30	60	2-3/4x6-1/2		32	60	(1-1/2x1-1/2) x 4 x 10			82-1/4	1727
BLT157272-FCF		72	72	36	72	3 x 7		36	72	(1-1/2x1-1/2) x 4 x 10			94-1/4	2213
BLT204848-FCF	20000	48	48	24	48	3 x 6		32	48	(1-1/2x1-3/4) x 4 x 10			70-1/4	1598
BLT206060-FCF		60	60	30	60	3 x 8		32	60	(1-1/2x1-3/4) x 4 x 10			82-1/4	2442
BLT207272-FCF		72	72	36	72	3 x 9		36	72	(1-1/2x1-3/4) x 4 x 10			96-1/4	2878
BLT307272-FCF	30000	72	72	36	72	3-3/4 x 9		42	72	(2x2-1/4) x 6 x 14			100-1/4	3706
BLT407272-FCF	40000	72	72	36	72	4 x 10		42	72	(2x2-3/4) x 6 x 14			100-1/4	4367
BLT507272-FCF	50000	72	72	36	72	4 x 12		42	72	(2-1/2x2-3/4) x 6 x 18			104-1/4	5790

- NOTES:
1. Maximum load length is equal to fork length.
 2. All fixed crane fork loads must be centered under the lifting bail.
 3. Please verify that the crane hook will fit the lifting bail size.
 4. Other capacities and lengths are available upon request.
 5. Above dimensions and weights are approximate and may vary based on design.